



NiteDevil HD-SDI Cameras

Stunning 1080p HD-SDI cameras with built in NiteDevil™ technology.



Anti-Vandal
CAM320-330



Traditional
CAM341-344



Covert
CAM350-351



Mini Bullet
CAM360-362



All-In-One IR
CAM380

**Handbook &
Instructions**



CAM380 - 2.1 Megapixel All-In-One IR
with a 2.8 - 11mm lens.

Introduction

The ever impressive NiteDevil technology is now built into a wide range of our HD-SDI cameras.

Our incredible 2.1 megapixel HD-SDI cameras record 1080p broadcast quality images at 25fps, that's 20x the quality of the average analogue alternative. Connect these cameras to one of our HD-SDI DVRs and you'll have an unrivalled CCTV system.

We offer a variety of HD-SDI cameras to suit any environment, from tiny module cameras and mini bullets to external all-in-one IR cameras.

As well as new systems, our HD-SDI cameras and alien DVRs offer a potential upgrade opportunity as they are designed to work over co-ax. By using co-ax cable already installed for an old analogue system it's easy to make the transition to HD-SDI.

CAM320
Ivory



CAM330
Chrome

MiRs
Maximum IR
Sensitivity



Available with wall bracket

Features

- 1080p at 25fps
- Low light 0.02 Lux (Sens-up)
- Dual Voltage, 12V DC, 24V AC
- Digital 64x Zoom
- Privacy Masking
- Wide Dynamic Range
- Internal Wiring

With its 1080p high-res image quality, this camera outputs the same stunning images as you would get from an HD TV programme. Additional NiteDevil technology gives it great low light performance.

FUNCTION	SPECIFICATION
Imaging Sensor	1/3" 2.1 Megapixel CMOS
Resolution	1080p 25fps
Lens Type	2.8 - 11mm Vari-focal
Min. Illumination	0.02 Lux (Sens-up)
Input Voltage	12V DC / 24V AC (Dual Voltage)

FUNCTION	SPECIFICATION
Current Consumption	150mA (12VDC) / 120mA (24VDC)
SN Ratio	More than 50dB
Video Connection	HD-SDI BNC Socket
Power Connection	Terminal Strip
Dimensions	144mm Dia x 100.5mm

CAM320/330 - Inside The Camera

OSD
Menu &
Settings Guide
Starts On Page 20

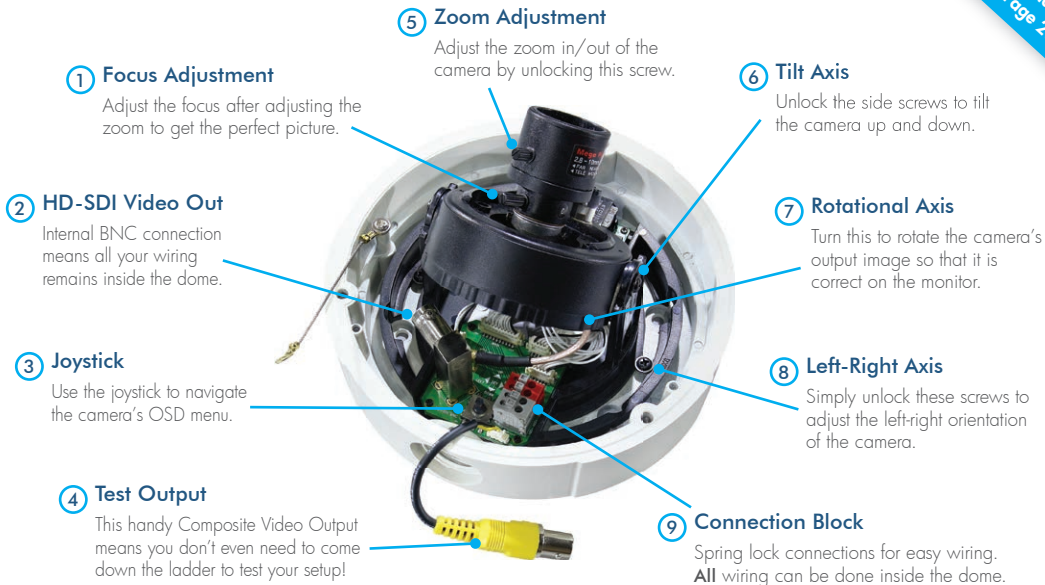

For more info, tips and advice visit nitedevil.com

CAM320/330 - Connecting The Camera Using RG59+4 (PTZ Combo Cable)

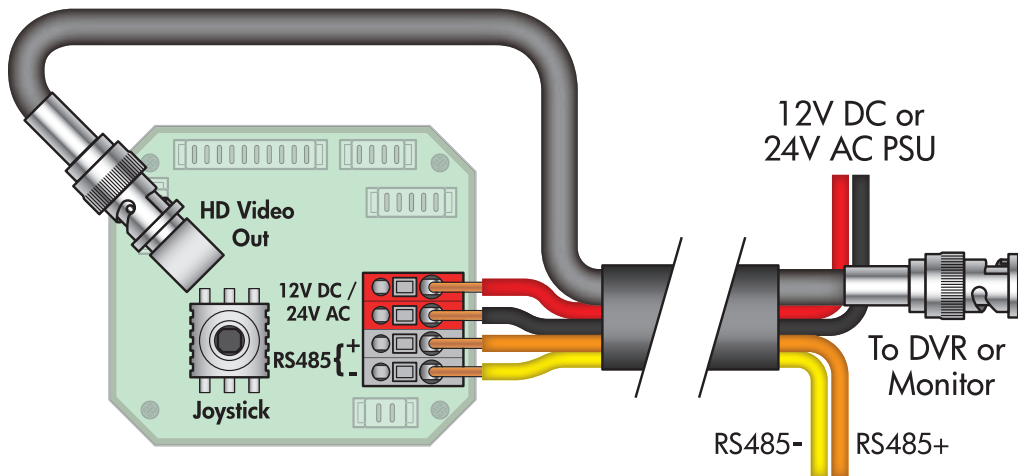

TIP

The power connection terminals (marked in red) are not polarity sensitive, therefore the power can be connected either way round. However, the RS485 connections are polarity sensitive and must be connected as shown in the diagram above.

To display the
OSD select Iris+
(Iris Open)

RS485 Keyboard
or Test Monitor
to control OSD

CAM320/330 - Mounting The Camera

The camera can be mounted on a wall, ceiling or attached to an optional wall bracket.

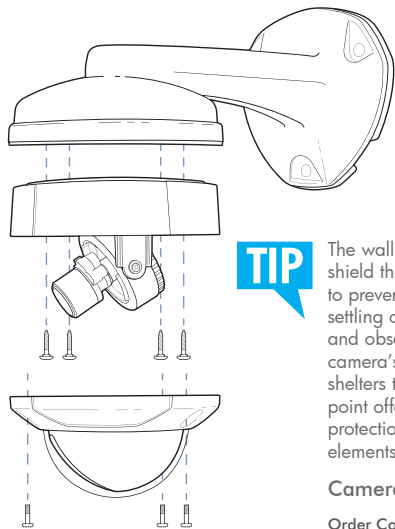

TIP

The wall bracket helps shield the camera to prevent rain from settling on the dome and obscuring the camera's vision. It also shelters the cable entry point offering better protection against the elements.

Camera & Bracket
Order Code: **CAM325**

To ensure that the camera is weatherproof, a rubber grommet is provided through which the cable enters the camera.

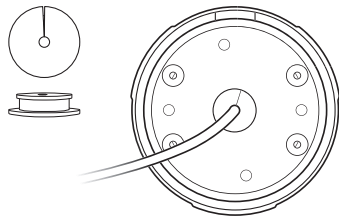

Prior to the end of the installation you need to additionally seal the grommet with a flexible silicone product. This is because the rubber grommet may shrink or get stressed over time.

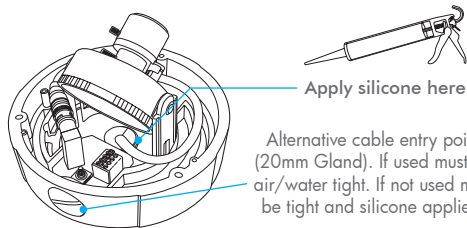

Alternative cable entry point (20mm Gland). If used must be air/water tight. If not used must be tight and silicone applied.

Accessing The Menus

To make life easier, all the HD-SDI cameras covered in this book have virtually the same simple menu system.

You can access the menus in the camera in two ways:

- 1 Menu control buttons on the rear of the camera or OSD menu controller.
- 2 RS485 control using a keyboard, DVR, or CCTVMate test monitor by selecting 'Iris+' (Iris Open). (CAM320, CAM341-344 & CAM380)

Menu Control Buttons

To access the menus using the Menu control buttons or OSD menu controller, simply press the SET button down and the menu will pop up on the camera's image. Use the arrow keys to navigate through the menus. Selection is made by pressing the set button.

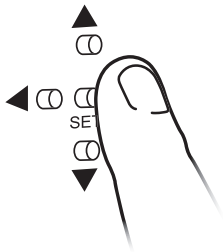

RS485

The CAM320 and the CAM341-344 range also has traditional RS485 PELCO-D control and has terminals to connect the RS485 control device to. PTZ keyboards, some DVRs or the CCTVMate test monitor all have RS485 control outputs that can control the camera. This method can be useful to adjust cameras remotely that are connected to DVRs.

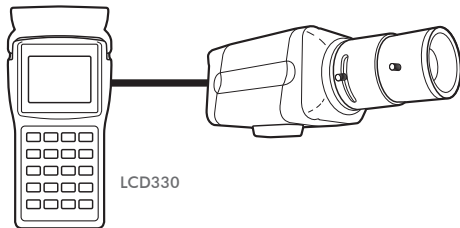

TIP When using a test monitor you must use the CVBS test output unless the test monitor specifies it is HD-SDI compatible.

Main Menu

Menu Structure

The following table shows the menu structure of the HD-SDI cameras covered in this book. Although all the cameras have an almost identical menu system, a few options may not be available on every camera.

Menu Style

There are 2 variations of the menu system used on our NiteDevil HD range of cameras. Any information marked with the number 2, as shown right, is only relevant for cameras which feature menu style 2.

2

MAIN MENU	SUB MENU	OPTION
LENS		DC / VIDEO / MANUAL
		DC: 1. MODE: INDOOR / OUTDOOR 2. RETURN: RET / END
EXPOSURE	SHUTTER	AUTO / MANUAL / FLK
		MANUAL: 1. LEVEL: 1/25 ~ 1/50000 / x2 ~ x60 2. RETURN: RET / END
	AGC	LOW / MIDDLE / HIGH
	AGC 2	0 ~ 15
	SENS-UP	AUTO / OFF
		AUTO: 1. SENS-UP: x2 ~ x60 2. RETURN: RET / END
	BRIGHTNESS	1 ~ 100
	D-WDR / ACCE	OFF / LOW / MIDDLE / HIGH
	D-WDR 2	ON / OFF
DEFOG	OFF / LOW / MIDDLE / HIGH	

MAIN MENU	SUB MENU	OPTION
EXPOSURE (CONTINUED)	DEFOG 2	ON / OFF
		ON: 1. POS / SIZE: POSITION → SIZE → RET / AGAIN 2. GRADUATION: OFF / LOW / MIDDLE / HIGH 3. DEFAULT 4. RETURN: RET / END
	BACKLIGHT	OFF / BLC / HSBLC
		BLC: 1. GAIN: LOW / MIDDLE / HIGH 2. AREA: POSITION → SIZE → RET / AGAIN 3. DEFAULT 4. RETURN: RET / END
	HSBLC 1. SELECT: AREA1 ~ 4 2. DISPLAY: ON / OFF ON: POSITION → SIZE → RET / AGAIN 3. LEVEL: 0 ~ 100 4. MODE: ALL DAY / NIGHT 5. BLACK MASK: ON / OFF 6. DEFAULT 7. RETURN: RET / END	
BACKLIGHT 2		OFF / WDR / BLC / HSBLC (FOR HSBLC SEE ABOVE)
	WDR:	1. GAIN: LOW / MIDDLE / HIGH 2. WDR OFFSET: 0 ~ 255 3. RETURN: RET / END (NOT SUPPORTED ON CVBS)
	BLC:	1. GAIN: LOW / MIDDLE / HIGH 2. AREA: POSITION → SIZE → RET / AGAIN 3. DEFAULT 4. RETURN: RET / END
WHITE BAL		ATW / AWC → SET / INDOOR / OUTDOOR / MANUAL
	MANUAL:	1. BLUE: 0 ~ 100 2. RED: 0 ~ 100 3. RETURN: RET / END
DAY & NIGHT		AUTO / COLOUR / B&W / EXT
	AUTO:	1. DELAY: 0 ~ 60 2. D → N (AGC): 0 ~ 100 3. N → D (AGC): 0 ~ 100 4. RETURN: RET / END

Main Menu Continued

2 - Options with this icon relate to the cameras which feature menu style 2.

MAIN MENU	SUB MENU	OPTION
DAY & NIGHT (CONTINUED)		B&W: <ol style="list-style-type: none"> BURST: ON / OFF IR SMART: ON / OFF ON: 1. LEVEL: 0 ~ 16 2. AREA: POSITION → SIZE → RET / AGAIN 3. RETURN: RET / END IR LED: ON / OFF IR PWM: 0 ~ 100 RETURN: RET / END
	2	EXT: <ol style="list-style-type: none"> DELAY: 0 ~ 20 EXT ACTIVE: LOW / HIGH RETURN: RET / END
NR	2DNR	ON / OFF
	3DNR	ON / OFF
		ON: <ol style="list-style-type: none"> S-LEVEL: 0 ~ 100 E-LEVEL: 0 ~ 100 RETURN: RET / END
	3DNR 2	ON / OFF
		ON: <ol style="list-style-type: none"> SMART NR: ON / OFF ON: 1. SENSITIVITY: 0 ~ 100 2. RETURN: RET / END LEVEL: 0 ~ 100 START.AGC: 0 ~ 100 END.AGC: 0 ~ 100 RETURN: RET / END
LEVEL	0 ~ 100	
SMART NR	ON / OFF	
SPECIAL	SEE PAGE 15	
ADJUST	SHARPNESS	<ol style="list-style-type: none"> SHARPNESS: ON / OFF LEVEL: 0 ~ 100 RESOLUTION: ON / OFF RETURN: RET / END

MAIN MENU	SUB MENU	OPTION
ADJUST (CONTINUED)	MONITOR	LCD / CRT
		LCD: 1. GAMMA: AUTO / USER1 / USER2 / 0.45 ~ 1 2. BLUE GAIN: 0 ~ 100 3. RED GAIN: 0 ~ 100 4. RETURN: RET / END
		CRT: 1. BLACK LEVEL: -30 ~ +30 2. BLUE GAIN: 0 ~ 100 3. RED GAIN: 0 ~ 100 4. RETURN: RET / END
	OSD	1. TEXT COLOUR: 1 ~ 8 2. OUTLINE: ON / OFF 3. RETURN: RET / END
	LSC	ON / OFF
	NTSC/PAL	NTSC / PAL
ADJUST 2		1. SHARPNESS: 0 ~ 15 2. MONITOR: LCD / CRT LCD: 1. GAMMA: USER / USER+Y / 0.45 ~ 1 / AUTO 2. ADAPT LEVEL: 0 ~ 100 3. BLUE GAIN: 0 ~ 100 4. RED GAIN: 0 ~ 100 5. RETURN: RET / END CRT: 1. BLACK LEVEL: -30 ~ +30 2. BLUE GAIN: 0 ~ 100 3. RED GAIN: 0 ~ 100 4. RETURN: RET / END 3. LSC: ON / OFF ON: 1. SCAN 2. RETURN: RET / END 4. VIDEO OUT: PAL / NTSC 5. RETURN: RET / END
RESET		1. FACTORY 2. RETURN: RET / END
RESET 2		FACTORY / CHANGE FACTORY: RESTORE DEFAULT SETTINGS CHANGE: SAVE CURRENT SETTINGS AS DEFAULT SETTINGS
EXIT		SAVE & EXIT

Special Menu

Special Sub Menu

The following table shows the 'Special' sub menu structure. Although all the cameras have an almost identical menu system, a few options may not be available on every camera.

Menu Style

There are 2 variations of the menu system used on our NiteDevil HD range of cameras. Any information marked with the number 2, as shown right, is only relevant for cameras which feature menu style 2.

2

SPECIAL MENU	SUB MENU	OPTION	
CAM TITLE		ON / OFF	
		ON: INPUT CAMERA NAME	
D-EFFECT	FREEZE	ON / OFF	
	MIRROR	OFF / MIRROR / V-FLIP / ROTATE	
	D-ZOOM	ON / OFF	
		ON: 1. PIP: ON / OFF 2. D-ZOOM: x2 ~ x64 3. PAN&TILT: PIP → D-ZOOM	4. DEFAULT 5. RETURN: RET / END
	SMART D-ZOOM	1. SELECT: AREA1 ~ 2 2. DISPLAY: ON / OFF ON: POSITION 3. SENSITIVITY: 0 ~ 60	4. D-ZOOM: x2 ~ x62 5. TIME: 0 ~ 15 6. DEFAULT 7. RETURN: RET / END
	NEG IMAGE	ON / OFF	
DIS	NOT SUPPORTED		

SPECIAL MENU	SUB MENU	OPTION
MOTION		<p>ON / OFF</p> <p>ON:</p> <ul style="list-style-type: none"> 1. SELECT: AREA1 ~ 3 2. DISPLAY: POSITION → SIZE → RET / AGAIN 3. SENSITIVITY: 0 ~ 60 4. MOTION VIEW: ON / OFF 5. DEFAULT 6. RETURN: RET / END
PRIVACY		<p>ON / OFF</p> <p>ON:</p> <ul style="list-style-type: none"> 1. SELECT: AREA1 ~ 8 2. DISPLAY: ON / OFF ON: POSITION → SIZE → RET / AGAIN 3. COLOUR: 1 ~ 16 4. DEFAULT 5. RETURN: RET / END
PRIVACY 2		<ul style="list-style-type: none"> 1. SELECT: AREAR1 ~ 8 2. DISPLAY: INV / MOSAIC / COLOUR / OFF INV: POSITION → TOP LEFT → TOP RIGHT → BOTTOM LEFT → BOTTOM RIGHT → RET / AGAIN MOSAIC: POSITION → TOP LEFT → TOP RIGHT → BOTTOM LEFT → BOTTOM RIGHT → RET / AGAIN COLOUR: POSITION → TOP LEFT → TOP RIGHT → BOTTOM LEFT → BOTTOM RIGHT → RET / AGAIN 3. COLOUR: 0 ~ 16 4. TRANS: 0 ~ 3 5. DEFAULT 6. RETURN: RET / END
LANGUAGE		ENG / JPN / CHN1 / CHN2
LANGUAGE 2		ENG / JPN / CHN1 / CHN2 / KOR / GER / FRA / ITA / SPA / POL / RUS / POR / NED / TUR / HEB / ARB

Special Menu Continued

- Options with this icon relate to the cameras which feature menu style 2.

SPECIAL MENU	SUB MENU	OPTION
DEFECT		1. LIVE DPC: ON / OFF / AUTO 2. LEVEL: 0 ~ 60 3. STATIC DPC: ON / OFF 4. START 5. LEVEL: 0 ~ 60 6. SENS-UP: x2 ~ x60 7. RETURN: RET / END
DEFECT 	LIVE DPC	ON / OFF / AUTO ON: 1. LEVEL: 0 ~ 100 2. RETURN: RET / END
	STATIC DPC	ON / OFF ON: 1. START 2. LEVEL: 0 ~ 60 3. SENS-UP: x2 ~ x30 4. AGC: 0 ~ 8 5. RETURN: RET / END
RS485		1. CAM ID: 0 ~ 255 2. ID DISPLAY: ON / OF ON: POSITION 3. BAUD RATE: 2400 / 4800 / 9600 / 19200 / 38400 4. RETURN: RET / END
VERSION		FIRMWARE VERSION
RETURN		RET / END

Getting The Most Out Of The NiteDevil HD-SDI Range What the menu options do

The NiteDevil HD-SDI range has a comprehensive menu system that allows you to set up the camera to get the most out of it in different demanding situations, below is a guide to some of the key functions:

Exposure

In the exposure settings you are able to adjust the shutter speed and sensitivity of the CCD to control how much light is collected by the camera. This allows you to configure the camera to achieve the best image possible based on the environment in which it is situated.

Shutter

Controls how long the CCD is exposed to light. A slow shutter (opened for longer periods of time) makes the image brighter but any movement may appear blurred.

The shutter speed can be set to auto so that it automatically adjusts to changes in light levels producing bright images all the time. You can also manually set the shutter speed so that it is tailored to the environment in which it is installed.

AGC (Automatic Gain Control)

AGC automatically adjusts the Video amplitude under various lighting conditions to maintain a bright image. You can choose

the level of amplitude however setting it too high could produce a noisy image in low light conditions.

Sens-Up

Sens-up technology makes the camera more sensitive to light giving better quality images in low light situations. You can set by how much the camera's sensitivity to light is intensified.

Backlight

Generally there are 3 backlight modes, WDR (Wide Dynamic Range), BLC (Backlight Compensation) and HSBL (High Suppression Backlight Compensation). All 3 modes are included on all camera models featured in this book. Each mode is designed to correct the brightness of the image in different environments as described below:

WDR Digitally adjusts the exposure in different parts of the image to maintain optimum levels in both the dark and the bright areas.

The strength of the WDR filter can be set to Low, Middle or High depending on the difference between the bright and dark areas of the image.

BLC Adjusts the exposure of the entire image to properly

Getting The Most Out Of The NiteDevil HD-SDI Range What the menu options do

expose a subject in the foreground when a bright light source, such as a window, is situated behind it.

You can choose the level of compensation for a bright background between Low, Middle and High as well setting the area of the camera's image for which to compensate.

HSBLC Masks areas of intense light to properly expose other areas of the image. For example a car's headlights would be masked reducing glare making the number plate visible.

When HSBLC is enabled the camera will automatically mask bright areas of the camera's image. Additionally you can manually set the size, position and strength of up to 4 masking areas.

White Balance

White balance is configured so that objects appear a natural colour. There are various ways this can be achieved as explained below.

ATW (Auto Tracking White Balance)

The white balance is continuously adjusted according to the colour temperature of the image.

AWC

Automatically sets the white balance by holding a white object such as a piece of paper or card in-front of the camera and pressing set.

Indoor

Makes allowances for artificial light sources and adjusts the image's colour accordingly.

Outdoor

Makes allowances for natural light sources and adjusts the image's colour accordingly.

Manual

Allows you to manually fine tune the white balance of the image.

Day & Night

In the day & night settings you can control if or when the camera switches between a colour and a black & white image.

NiteDevil technology can still produce a colour image in low light situations, however, in extremely low light situations

Getting The Most Out Of The NiteDevil HD-SDI Range What the menu options do

switching to a black & white image could produce a better quality image.

Auto

Auto is the most commonly used option. The camera will automatically switch to a black & white image when it detects light levels have dropped below a usable level.

A delay can be set of up to 60 seconds which will instruct the camera to wait for the set length of time before switching. This accommodates for any temporary drops in light such as passing clouds.

The gain can also be telling the camera to increase or decrease the video amplitude when switching from day to night and night to day.

Colour

The camera is forced to permanently produce a colour image. This is great in environments where there is constant light but could result in poor quality images in low light situations. As long as the camera is in colour mode the IR LEDs will not turn on.

B & W (Black & White)

The camera will permanently produce a black & white image.

This is only recommended in areas where the light levels are always extremely low.

There are various settings to ensure the camera produces the best B & W image possible. Burst compensates for sudden changes in light levels. IR Smart closes the iris when a subject is close to the camera to darken the image and prevent over saturation. You also have the option to enable and disable the IR LEDs.

Ext (External) **2**

The switch between colour and black & white is controlled by an external trigger such as a photocell.

Again a delay can be set which will instruct the camera to wait for a set length of time before switching. This accommodates for any temporary drops in light

Privacy

Allows the user to “block out” up to 8 areas in the picture so that the installation complies with the Data Protection Act and avoids infringing other people’s privacy rights. This could be used to block out windows on a neighbouring property or screens and signs that display sensitive information.

D-Zoom

Enables the user to digitally zoom in on an area of the image if the optical lens is not quite enough. PIP (Picture In Picture) can be enabled so that a small window showing the original size image is overlaid onto the screen when zoomed in.

Smart D-Zoom 2

Allows the camera to be set up to “automatically” zoom in when it detects movement in a certain area. This can be used to get a closer view of faces or number plates.

The area, sensitivity and level of zoom can all be set.



Movement detected



Automatic Digital Zoom

NR (Noise Reduction)

Noise reduction is the process of applying a filter to the image to reduce noise from the video signal. There are a number of NR options as explained below.

Level

Is a basic filter to reduce small amounts of noise from the foreground of the image.

2DNR

Applies a digital filter to reduce noise from the foreground of the camera's image.

3DNR

Applies a digital filter to reduce noise from both the foreground and the background of the camera's image even in low light conditions.

Setting the level determines how strong a filter is applied and the sensitivity sets the tolerance as to what is considered noise.

Smart NR

Enabled will reduce noise with very little loss of detail.

Fault Finding

Every NiteDevil camera is built to the highest standards and is fully tested prior to packing so if you experience an installation problem you need to investigate your cabling, connections, power supply and monitor.

No picture from the HD-SDI

There are a number of potential problems that could cause this.

Step 1 The camera can not function without the correct power supply.

- A. Test that the camera has the correct voltage supplying it, you must do this with the camera connected so that there is load on the PSU. A 12V DC camera should have at least 10.5V DC connected to it. 24V AC cameras should have at least 21.5V AC connected to them.
- B. For 12V DC cameras only ever use regulated power supplies so that you can be sure that the camera is always receiving the correct voltage.



See online [Tip 259](#) for the 'Dos And Don'ts Of Power Supplies' at nitedevil.com.

Step 2 Check there is a picture coming out of the CVBS test output at the camera. If there is a picture here but not at the DVR it could be one of the following:

- A. Video loss in composite cable as the run is too long. Usually you would get a picture up to around 100mtrs with HD-SDI. Anything above this would require a HD-SDI repeater (featured on [page 35](#)) every 100mtrs.
- B. Check the quality of the cable used. For best results, especially with HD-SDI, use a cable with a solid copper core such as our [antihum branded cable on page 37](#). Cable with a solid copper core suffers far less signal loss than cheaper, inferior cable which only has a copper coated core.

Fault Finding

- C. Ensure that the BNC - BNC lead that you connect between the camera and monitor has no shorts or open circuits. If you are making your own lead, don't forget the lead must have two wires connected to complete the circuit, Video and Ground.
- D. Ensure all connections to both the camera and DVR are firm and secure.
- E. Make sure that there are no tight bends or loops in the cable. The minimum bend radius for RG59 co-ax cable is 60mm.



See online [Tip 300](#) for our 'Top Tips When Installing Cable' and [Tip 281](#) for the 'Dos And Don'ts For Running Co-ax' at nitedevil.com.

Test monitor doesn't display an image

Make sure the test monitor is connected to the camera's CVBS test output and not the HD-SDI output. A lot of test monitors do not accept HD-SDI signals.

Can't control via 2 wire RS485

If your camera seems unresponsive when attempting to control it via RS485 check the following.

- A. RS485 wires crossed over, try swapping around.
- B. Wrong protocol and baud rate selected.

10 Reasons the alienHero HD DVR is great value for money

alienHero HD 8ch



1. **1080p Recording** (*broadcast quality*)
2. **Built-in Video Analytics** (*finds evidence instantly!*)
3. **High Definition HDMI Output** (*along with VGA*)
4. **Easy to Use Interface** (*said to be best in class*)
5. **AutoPort Plug-and-Play** (*for easy internet setup*)
6. **Compact Space Saving Case** (*slim modern design*)
7. **Free Dynamic DNS Setup** (*saves you time*)
8. **Full Alarm Inputs** (*8 on the 8 way*) - (*triggered how you want*)
9. **Bespoke Software Available** (*you want it, we write it*)
10. **Video Tagging** (*tag recording with keywords such as "theft"*)

Order Codes

4ch 2TB: ALIEN674N

8ch 2TB: ALIEN678N

Other Products To Consider - HD-SDI Transmission Solutions

HD-SDI to HDMI Converter



Order Code: **HDM050**

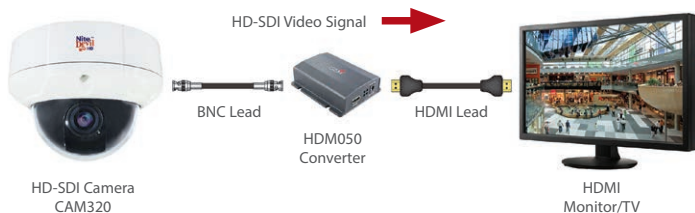

Ideal for converting the HD-SDI output of a camera into an HDMI output for direct connection into an HDMI monitor. This unit requires a minimum 180mA 12V DC power source.

HD-SDI Repeater For Extra Long Cable Runs



Order Code: **HDM100**



This handy HD-SDI repeater unit helps extend cabling runs of HD-SDI products by boosting the HD signal to allow an additional 100M of cabling for each repeater. Multiple units can be used on one cable run up to a maximum of 4. Quick to install, these units have a standard BNC input and output and require a minimum 100mA 12V DC power source.

Find out more at nitedevil.com

Other Products To Consider - HD-SDI Accessories

HDMI Monitors



HDMI LED-backlit LCD monitor in a range of sizes with HDMI, VGA & DVI inputs.

22" Monitor: [LCD822](#)

24" Monitor: [LCD824](#)

27" Monitor: [LCD827](#)

HDMI Socket Adaptor



This adjustable HDMI socket adaptor is great for saving space on rack mount installations.

Order Code: [VID500](#)

HDMI Leads



- High Quality CCTV Images
- 24k Gold Connections
- Range Of Sizes

Our HDMI leads have 24k gold connections for great image quality.

1m HDMI Lead: [VID501](#)

2m HDMI Lead: [VID502](#)

3m HDMI Lead: [VID501](#)

4m HDMI Lead: [VID504](#)

5m HDMI Lead: [VID510](#)

Megapixel Direct Drive Lenses



Megapixel direct drive lenses offer the lens quality needed to capture stunning HD images.

3.5-8mm DC Iris 1/3": [MPL300](#)

2.8-12mm DC Iris 1/3": [MPL312](#)

5-50mm DC Iris 1/3": [MPL350](#)

Other Products To Consider - Cable & Accessories

Antihum RG59+2

Cables can be separated for fast, easy installation

Glued foil sheath provides maximum protection against interference and prevents "loose" foil shorting to the centre pin

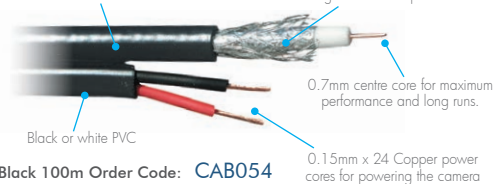

Black 100m Order Code: CAB054

White 100m Order Code: CAB040

Antihum RG59+4

Glued foil sheath provides maximum protection against interference and prevents "loose" foil shorting to the centre pin

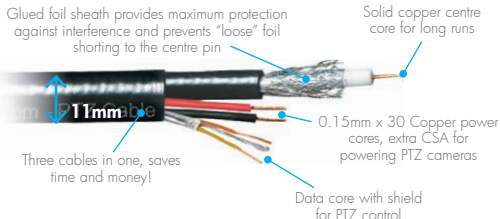

Black 150m Order Code: CAB060

3pc BNC Crimps



These traditional 3-piece BNC crimp-on plugs are the popular choice for CCTV Installers.

100pk: CON430

100pk Individually Wrapped:
CON450

Interceptor CCTV Housing Kit



Attractive housing, dual voltage, low current heater, strong cable managed bracket, accessories and fixings tub, 3x A4 CCTV warning signs with free registration onto the Who Is Watching Me data compliance scheme.

Order Code: CCT470

For more information visit www.antihum.com

Other Products To Consider - Useful Tools

BNC Ratchet Crimp



Crimps - 2pc✓ 3pc✓ Mini 3pc✓



Order Code: TOO980

Learn how to crimp a BNC! See online tip 248

CCTV Test Monitor

cctvmate.com



- PTZ Control Testing
- DC/AC Voltage Tester
- RS485 Data Test Function
- 29 Protocols Supported
- Check Video Signal Strength
- 12V Camera Power Function
- Up to 10 Hours Battery Life
- Network Cable Testing
- Monitor Output Testing

Kit includes:



Carry case, DC/AC Voltage probes, RS485 Data test cable, Camera power cable, BNC Lead, Neck strap, Network cable tester & PSU.

Order Code: LCD330

Other Products To Consider - Rack Mount Power Supplies

12V DC 10-Amp PSU With 18 Outputs



Regulated 12V DC 10 Amp 1.5U rack mount power supply with 18 outputs. Each output supplies up to 1.1A with a maximum output of 10A across all ports.

Order Code: POW560

12V DC 20-Amp PSU With 18 Outputs



Regulated 12V DC 20 Amp 1.5U rack mount power supply with 18 outputs. Each output supplies up to 2A with a maximum output of 20A across all ports.

Order Code: POW562

24V AC 10-Amp PSU With 18 Outputs



A 24V AC 10 Amp 1.5U rack mount power supply with 18 outputs. Each output supplies up to 1.1A with a maximum output of 10A across all ports.

Order Code: POW565

24V AC 20-Amp PSU With 18 Outputs



A 24V AC 20 Amp 1.5U rack mount power supply with 18 outputs. Each output supplies up to 2A with a maximum output of 20A across all ports.

Order Code: POW566

For more information visit www.antihum.com



NiteDevil CCTV - Cameras That See In The Dark!

You can find **everything you need** and more at nitedevil.com

Live Chat Available



As well as information and spec on all our cameras, we offer a wide range of support to help you get the most out of your NiteDevil equipment.

- Live Chat
- Tips
- FAQs
- Manuals
- Marketing Resources
- Tools
- How To Guides
- Software Downloads
- Videos
- Training Courses
- Trade Enquiries

nitedevil.com

All specifications are approximate. We reserve the right to change any product specifications or features without notice. Whilst every effort is made to ensure that these instructions are complete and accurate, NiteDevil cannot be held responsible in any way for any losses, no matter how they arise, from errors or omissions in these instructions, or the performance or non-performance of the equipment that these instructions refer to.



WEE/CG0783SS

This symbol on the products and/or accompanying documents means that used electronic equipment must not be mixed with general household waste. For treatment, recovery and recycling please return this unit to your trade supplier or local designated collection point as defined by your local council.